

Double-Ended Shear Beam Load Cell

FEATURES

- Rated capacities of 10,000 to 100,000 pounds
- Center-link loaded
- Integral conduit adaptor
- Trade certified for NTEP Class III: 10000 divisions; Class III: 5000 divisions and OIML R60 3000 divisions in 20,000 to 100,000 pounds range
- *Sensorgage™* sealed to IP67 standards
- Factory Mutual System Approved for Classes I, II, III; Divisions 1 and 2; Groups A through G. Also, non-incendive ratings (No barriers!).
- **Optional**
 - 65058S stainless steel, welded seal version available
 - 65058-TSA companion assemblies for vehicle scales
 - 65069-TWA companion assemblies for vessel weighing
 - Capacities up to 500,000 consult factory



65058-TSA

65069-TWA



DESCRIPTION

The 65058 is a mid to high capacity, nickel-plated alloy steel, double ended Shear beam load cell.

This product is designed for use in certified truck and rail scales and is available in capacities ranging from 10k to 100k lbs.

This load cell is rated intrinsically safe by the Factory Mutual System (FM); making it suitable for use in potentially explosive environment.

This load cell is certified for legal for trade applications by both American NTEP and International OIML standards.

APPLICATIONS

- Truck scales
- Railroad track scales
- Precision tank, bin and silo weighing
- Level and inventory monitoring

OUTLINE DIMENSIONS in inches

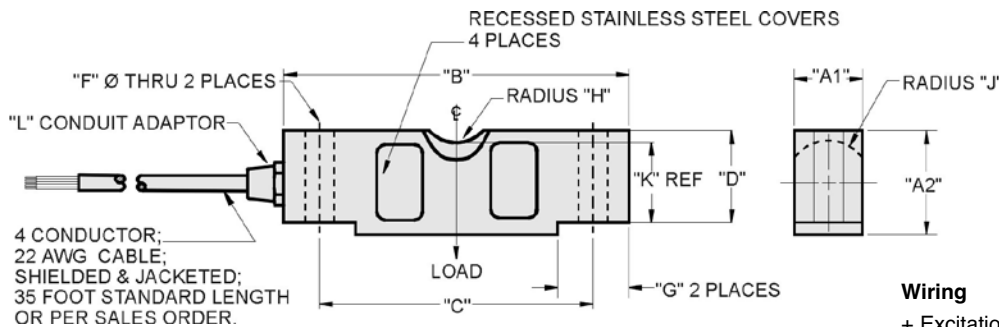

Wiring

+ Excitation	Red
- Excitation	Black
+ Output	Green
- Output	White

CAPACITY	A1	A2	B	C	D	F	G	H	J	K	L
10k-25k	1.69	1.94	7.75	6.50	1.70	0.68	1.38	0.75	0.90	1.63	1/4 - 18 NPT
40k	1.94	2.44	10.25	8.50	2.10	0.81	1.93	1.00	1.12	2.00	1/4 - 18 NPT
50k-75k	2.44	2.94	10.25	8.50	2.65	1.06	1.93	1.00	1.37	2.54	1/2 - 14 NPT
100k	2.90	3.86	15.25	12.75	3.43	1.62	3.13	1.50	1.80	3.30	1/2 - 14 NPT

Capacities are in pounds.

Double-Ended Shear Beam Load Cell

SPECIFICATIONS					
PARAMETER	VALUE				UNIT
Rated capacity—R.C. (E_{max})	10k, 25k, 40k, 50k, 60k, 75k, 100k ⁽¹⁾				lbs
NTEP/OIML accuracy class	NTEP III	NTEP IIIIL	Standard	OIML R60	
Maximum no. of intervals (n)	5000 multiple	10000 multiple		3000	
Y = E_{max}/V_{min}	See NTEP cert. 86-046A3			6667	Maximum available
Rated output—R.O.	3.0				mV/V
Rated output tolerance	0.25				±% mV/V
Zero balance	1.0				±% FSO
Combined error	0.02	0.02	0.03	0.02	±% FSO
Non-repeatability	0.01	0.01	0.015	0.01	±% FSO
Creep error (30 minutes)	0.025	0.030	0.03	0.017	±% FSO
Temperature effect on zero	0.0010	0.0010	0.0015	0.0010	±% FSO/°F
Temperature effect on output	0.0008	0.0008	0.0008	0.0007	±% of load/°F
Compensated temperature range	14 to 104 (–10 to 40)				°F (°C)
Operating temperature range	0 to 150 (–18 to 65)				°F (°C)
Storage temperature range	–60 to 185 (–50 to 85)				°F (°C)
Sideload rejection ratio	500:1				
Safe sideload	100				% of R.C.
Maximum safe central overload	150				% of R.C.
Ultimate central overload	300				% of R.C.
Excitation, recommended	10				VDC or VAC RMS
Excitation, maximum	25				VDC or VAC RMS
Input impedance	686–714				Ω
Output impedance	699–707				Ω
Insulation resistance at 50 VDC	>1000				MΩ
Material	Nickel-plated alloy tool steel ⁽²⁾				
Environmental protection	IP67				

Notes

- ⁽¹⁾ Consult factory for capacities over 100k
NTEP approval 20-200k lbs only
 - ⁽²⁾ Stainless steel available—model name is 65058S
- FSO—Full Scale Output
All Specifications subject to change without notice.



Disclaimer

ALL PRODUCTS, PRODUCT SPECIFICATIONS AND DATA ARE SUBJECT TO CHANGE WITHOUT NOTICE.

Vishay Precision Group, Inc., its affiliates, agents, and employees, and all persons acting on its or their behalf (collectively, "VPG"), disclaim any and all liability for any errors, inaccuracies or incompleteness contained herein or in any other disclosure relating to any product.

The product specifications do not expand or otherwise modify VPG's terms and conditions of purchase, including but not limited to, the warranty expressed therein.

VPG makes no warranty, representation or guarantee other than as set forth in the terms and conditions of purchase. **To the maximum extent permitted by applicable law, VPG disclaims (i) any and all liability arising out of the application or use of any product, (ii) any and all liability, including without limitation special, consequential or incidental damages, and (iii) any and all implied warranties, including warranties of fitness for particular purpose, non-infringement and merchantability.**

Information provided in datasheets and/or specifications may vary from actual results in different applications and performance may vary over time. Statements regarding the suitability of products for certain types of applications are based on VPG's knowledge of typical requirements that are often placed on VPG products. It is the customer's responsibility to validate that a particular product with the properties described in the product specification is suitable for use in a particular application. You should ensure you have the current version of the relevant information by contacting VPG prior to performing installation or use of the product, such as on our website at vpgsensors.com.

No license, express, implied, or otherwise, to any intellectual property rights is granted by this document, or by any conduct of VPG.

The products shown herein are not designed for use in life-saving or life-sustaining applications unless otherwise expressly indicated. Customers using or selling VPG products not expressly indicated for use in such applications do so entirely at their own risk and agree to fully indemnify VPG for any damages arising or resulting from such use or sale. Please contact authorized VPG personnel to obtain written terms and conditions regarding products designed for such applications.

Product names and markings noted herein may be trademarks of their respective owners.

Copyright Vishay Precision Group, Inc., 2014. All rights reserved.